

STANDARD SPECIFICATIONS

MODEL DESIGNATION CHU602

ENGINE: MACK MP8-425E

Peak Horsepower – 425HP at 1500-1800 RPM
Horsepower – 425 HP at 1800 Gov. RPM
Max. Torque – 1560 lb/ft at 1200 RPM
V-MAC IV – Total Vehicle Electronics
Air Compressor – Meritor/WABCO 318 (18.7 cfm)
Air Cleaner, 11" Single Element
Dry Type, Under Hood
Air Intake from Both Sides of Hood
Alternator, 12V 100A – Delco (24SI)
Batteries, (3) Mack 12V M/F Group – 650 CCA
Total 1950 CCA w/Kalas Cables
Coolant Protection - 34°F (-37°C)
Mack Coolant Conditioner
Diesel Particulate Filter – Vertical RH Side Back of Cab
Exhaust After Treatment System, Ceramic Catalyzed
Engine Brake – Mack Powerleash
Silicone Engine Hoses and Tubing
Poly-V Fan Belt w/Automatic Tensioner
Fan Drive, Electronically Modulated Type
Flywheel Housing, Aluminum
Fuel Water Separator
Mack EPDM Radiator & Heater Hoses
Aluminum Radiator
Starter, 12V Gear Reduction
Electronic Starter Interlock

CLUTCH: EATON/FULLER, CL798

15.5" Two-Plate w/Dampened Ceramic Coax
Manual Adjust
9-Spring 4-Paddle Driven Disc & 2" Diameter Spline

TRANSMISSION: FULLER, FRO-15210B

10-Speed, Ratios: 11.06 Low – 0.75 High
Driveline: Meritor 176N w/Coated Splines

CAB: CA68 CONVENTIONAL

Air Conditioner w/Integral Heater – R134a Refrigerant
Air Restriction Monitor, Graduated Lock Up Type
Air Cleaner Intake Mounted
Ash Tray
Cab Mounting
Four Point System w/2 Air Bags and Shocks at Rear
Cigar Lighter
Coat Hook (1)
Cup Holders, Driver's & Rider's Side
Dome Lights, 2 Lamps LH/ 2 Lamps RH
Doors, Galvanized Steel w/Visibility Door
Engine Shutoff – Key Type Control
Floor Mats, Mack Signature Polyurethane
Air Pressure Gauges – Primary & Secondary
Voltmeter - Digital
Gauge Cluster:
Exhaust Pryometer and Transmission Oil
Temperature Gauges
Engine Coolant Temperature Gauge
Engine Oil Pressure Gauge
Fuel Level Gauge
Speedometer, Electronic w/Trip Odometer
Engine Tachometer Electronic w/Hourmeter
Safety Tinted Windshield, Side and Rear Windows
Grab Handles, Black Finish RH & LH Behind Door
HeadLamp Bezel – Molded Plastic, Bright Finish

MACK

PINNACLE AXLE FORWARD 4X2 SERIES



- Conventional Cab
- Front Axle Forward
- 4-Wheel Tractor
- ABS (Anti-Lock Brake System)

The MACK Pinnacle Axle Forward is for fleet owner and owner-operator alike, a total chassis optimized through computer-aided design for an excellent strength-to-weight ratio. The cab incorporates exceptional room and comfort with the highest standards of fit and finish. Available with or without one of the integrated sleepers with unified aerodynamics. Either way the cab ride is an innovative cab air suspension, with a sleeper subframe for unsurpassed smoothness and comfort. The quiet roomy interior caters to the driver's every need.

STANDARD

ENGINE: MACK MP8-425E
425 HP Peak Horsepower

TRANSMISSION: FULLER, FRO-15210B
10-Speed

FRONT AXLE: MACK FXL12
12,000 lb. Capacity

REAR AXLE: MERITOR RS-23-161
23,000 lb. Capacity
Suspension: Multileaf Spring



STANDARD SPECIFICATIONS

(Continued)

CAB: CA68 CONVENTIONAL (Continued)

Horn, Air Horn Single Tone Electronic
Identification and Clearance Lights (5)
Instrument Cluster:
 Segmented LCD Driver's Display
Instrument Panel, Charcoal Gray
Interior Trim: Genuine – Slate Gray
Keys, 2 – Keyed at Random
Low Air Pressure Indicator, Light and Buzzer
Exterior Mirrors, Body Colored Aero Mirrors w/Integrated
 Convex Mirror
Parking Brake On Indicator Light
Radio Accommodation Package
 Includes: Antenna, Power Supply and 2 Speakers
CB – 5 way Binding Post
Seating:
 Driver – Bostrom Talladega 915 Mid-Back Air Suspension
 Rider – Mack Fixed Mid-Back Non-suspension
Seat Belts, Lap and Shoulder w/Cab Mounted Shoulder Belt
 w/Fixed D-Ring for Driver and Rider Seats
Side Markers – Lamps and Reflectors
Key Type Starter Switch
Steering Column, Adjustable Tilt Telescope
Steering Wheel, Two Spoke Urethane Grip Painted Spokes and
 Bulldog Horn Cap
Overhead Console, 3 Storage Compartments w/Nets
Rear Storage Pouch
Sun Visor, Interior Both Sides w/Ticket Holder
Turn Signals, Integral w/Fender
Window Control, Standard Hand Crank
Windshield – 2 Piece
Windshield Washers, Wiper Mounted w/Reservoir
 Mounted under Hood
Windshield Wipers:
 2 Speed Electric Motor w/Intermittent Feature

HOOD & FENDERS:

One Piece Fiberglass
SMC (Sheet Molding Compound)
Grille, Bright Finish (Chrome) w/Black Background

FRAME:

Wheelbase (WB) – 166"
Load Platform (LP) – 117"
Cab to Axle (CA) – 78"
Axle to End of Frame (AF) – 39"
Frame Rails – Steel
Cross Section – 10.47" x 3.54" x .24"
Section Modulus, 11.6 in.³
RBM (per rail) – 1,390,000 lb. in.
Tapered and Flanged Rail Ends - 28°
Bumper: Stainless Steel Clad Aluminum Flush Mounted
Bumper to Back of Cab (BBC) – 116"
Fifth Wheel: Fontaine SL3ASB Air Slide
Front Towing, Clevis (2)

FUEL TANKS:

Capacity/Location: 93 Gallon LH & RH
Unpainted Aluminum, 26" Diameter

FRONT AXLE: MACK FXL12

12,000 lb. Capacity
Tires: 295/75R22.5 (Low Profile)
Wheel Equipment: (2) 22.5" x 8.25" Alcoa 10-Hole Hub
 Piloted Aluminum Disc, 11¼" Bolt Circle
Brakes: Meritor "S" Cam 15"x 4" Q-Plus w/o Dust Shields
Shock Absorbers
Slack Adjusters – Automatic
Suspension:
 Mack Taperleaf 12,000 lb. Ground Load Rating
 2 Leaf Spring
Steering: HD94 Sheppard Integral Power Steering

REAR AXLE: MERITOR RS-23-161

23,000 lb Capacity
Carrier – Malleable Housing
Suspension – Mack Multileaf 23,000 lb Capacity
Tires: 295/75R22.5 (Low Profile)
Wheel Equipment: (4) 22.5x8.25 Alcoa 10-Hole Hub Piloted,
 Aluminum Disc, 11¼" Bolt Circle
Brakes: Meritor "S" Cam 16.5" x 7" Q-Plus w/o Dust Shields
Wheel Seals – Oil
Slack Adjusters – Automatic
Spring Brake Chambers:
 (2) 30/30 Double Diaphragm Type, Mechanical Spring Release

AIR/BRAKE:

Dual Air Brake System
Air Dryer – Meritor System Saver 1200P
Air Reservoirs – Steel 5,600 in³ Capacity
 Single Compartment Primary and Two
 Compartment Supply/Secondary
Mack Road Stability Advantage System
Brake Control – 2 Valve Dual Brake System
 Trailer Supply and Tractor-Trailer Park
Hand Control Valve for Trailer Brake
Trailer Connection Package: Semi
 (2) 12' Air Hoses w/Integral Glad Hand Electrical Plug Holder
 Storage Bracket
 (1) 12' Seven Wire Cord w/Seven Wire Plug on Each End
 Ground Reachable,
 Breakaway Safety Valve
 Conspicuity Treatment to Back of Cab

ELECTRICAL:

Battery Box – Steel w/Molded Plastic Cover
 Mounted Forward of LH Fuel Tank
Courtesy Light Switch – Headlamp and Clearance
Daytime Running Lights
Doubles Trailer Electrical Package
Electric Circuit Protection Package
Waterproof Electrical Connections
Rear Lighting – (2) Combination Stop, Tail Directional and
 Back-Up Lights
Headlights, Halogen-Single Rectangular Replaceable Bulbs
Transistorized Turn Signal Flasher

PAINT:

Cab, Hood and Fenders:
 Mack White (High Gloss)
 Urethane Base Coat w/o Clear Coat
Chassis Running Gear:
 Mack Black (Urethane)

WEIGHT:

Font: 7,752
Rear: 4,635
TOTAL: 12,387

CHASSIS SPECIFICATIONS

(All measurements are in inches)

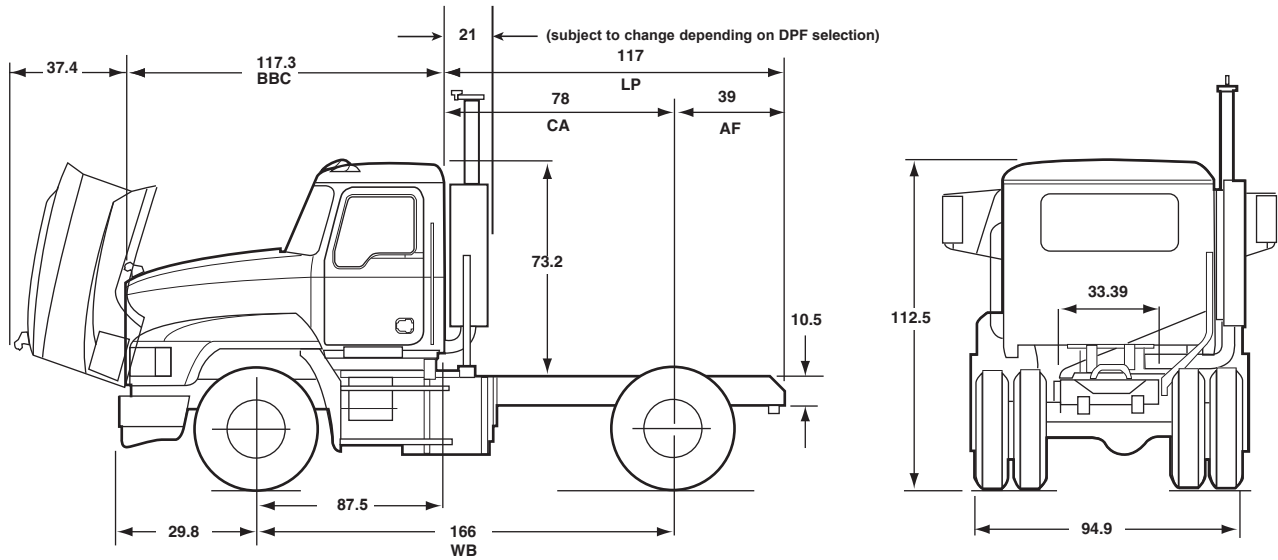

AVAILABLE DRIVELINE COMPONENTS

MP8—ENGINES	
MODEL	HORSEPOWER
MACK	
MP8-425E	425 HP [317 kW] @ 1500-1800 RPM 425 HP [317 kW] @ 1800
MP8-455E	455 HP [339 kW] @ 1500-1800 RPM 455HP [339 kW] @ 1800
MP8-485E	485 HP [362 kW] @ 1500-1800 RPM 485 HP [362 kW] @ 1800
MP8-415C	415 HP [309 kW] @ 1500-1700 RPM 390 HP [291 kW] @ 1950
MP8-445C	445 HP [332 kW] @ 1500-1700 RPM 420 HP [314 kW] @ 1950
MP8-485C	485 HP [362 kW] @ 1500-1700 RPM 455 HP [339 kW] @ 1950

TRANSMISSIONS		
MODEL	SPEEDS	RATIOS (LOW/HIGH)
MACK		
T306G	6	7.50/0.71
T309	9	11.40/0.71
T309(LR)	9	13.93/0.71
T310	10	13.81/0.73
T310M	10	17.35/0.73
T310ME	10	17.35/0.73
T313	13	13.44/0.74
T313 LR	13	16.42/0.71
T318	18	13.44/0.71
T318LR	18	16.42/0.71
ALLISON		
4000-HS	5	3.51/0.74
4000-RDS	5	3.51/0.74
4000-HS	6	3.51/0.64
4000 RDS	6	3.51/0.64
EATON FULLER		
RTX-16709B	9	12.46/0.73
FRO-15210B	10	11.06/0.75
FRO-15210C	10	12.69/0.74
FRO-16210B	10	11.06/0.75
FRO-16210C	10	12.69/0.74
RTO-16908LL	10	14.56/0.74
RTO-16910B-AS3	10	10.69/0.74
RTO-16910B-DM3	10	10.96/0.74
RTO-16910C-AS3	10	12.80/0.73
RTLO-16913A	13	12.31/0.73
RTO-16915	15	13.31/0.79
RTLO-16918A-AS3	18	14.40/0.73
RTLO-16918B	18	14.40/0.73

AXLES		
CAPACITY	MAKE	MODEL
FRONT AXLES		
12,000 lb. [5 443 kg]	MACK	FXL12
	DANA SPICER	E1202-LMS
	MERITOR	FF961
14,600 lb [6 623 kg]	MACK	FXL 14.6
	MERITOR	FG941
SINGLE REAR AXLES		
23,000 lb. [9 072 kg]	MACK	RA23R
	DANA SPICER	S23-190
	MERITOR	RS-161/186

OPTIONAL EQUIPMENT

FRAME:

Rail Dimensions: 10.47" x 3.54" x .28"
Section Modulus: 13.3 in.³
Resistance Bending Moment (RBM) 1,600,000 lbs. in.

Rail Dimensions: 10.47" x 3.54" x .32"
Section Modulus: 15.0 in.³
Resistance Bending Moment (RBM) 1,810,000 lbs. in.

Wheelbase Availability: 154" to 183"

CAB, OPTIONAL INTERIOR TRIM LEVELS:

Trim Level II – Custom: Refer to MackTraQ for complete description
Trim Level III – Grand Touring: Refer to MackTraQ for complete description

SLEEPER BOXES: Interior Color Matches that of the Cab Interior

48" Flat Top
56" Flat Top
60" Mid Rise
70" Mid Rise
70" High Rise

AERO AIDS:

Roof Fairings
Side Shields

OTHER OPTIONAL EQUIPMENT:

ABS Options	Engine Starting Aid	Sliding Rear Window
Aerodynamic Aids	Fifth Wheel & Related Equipment	Starter Option
Air Dryer Options	Fire Extinguisher	Steering Wheel Options
Air Horns	Fog Lights	Stereo Radio Options
Air Reservoir, Aluminum	Fuel Heater	Storage Console
Alternator Options	Gauge Cluster Options	Sun Visor, Exterior
Back of Cab Reflectors	Hood Insulation	Synthetic Lubricants
Back-Up Alarm	Hubodometer	Trailer Hook-Up Lamp
Batter Box Cover, Aluminum	Identification/Clearance Lights	Wheel Equipment Options
Battery Disconnect Switch	In-Dash Storage	Wheel Lugwrench
Battery Options	Instrument Panel Trim	Windshield Curtain
Brake Equipment Options	Keyed Alike Chassis	
Bright Finish Exhaust	Keyless Entry	
Bright Finish Fuel Tanks	Metric Gauges	
Bug Screen	Mirror Options	
Cab Window Options	Mud Flaps	
CB Radio Options	Overhead Console, 2 Compartments	
Coolant Protection	Permit Plates	
Co-Pilot Driver Information Display	Personalized Name Plate	
Crossmember Options	Power Windows & Locks	
Dash Mounted Switches	Push Button Start	
Door Interior Trim Panels	Quarter Fenders	
Dual Exhaust	Reflector Kit	
Engine Block Heater	Seat Options, Driver & Rider	
	Side Shield Extensions	